

# **Barrier-free Mobility and Public Transport Legal Aspects in Switzerland**

Hanspeter Oprecht, Federal Office of Transport

Senior Citizen Mobility Conference, September 9 2009, Hanspeter Oprecht, Federal Office of Transport

**Slide 1**

**Modern society means senior-friendly  
and disabled-friendly society.**

**Modern public transport should be - for  
this reason – *barrier-free*.**

**Establishing *barrier-free* public transport  
is however a challenge**

Senior Citizen Mobility Conference, September 9 2009, Hanspeter Oprecht, Federal Office of Transport

**Slide 2**

## **in force since 1<sup>st</sup> January 2004:**

- **Swiss Federal Act on the Elimination of Discrimination against People with Disabilities (DDA; d:BehiG; f:LHand)**
- **Ordinance on the Adaptation of Public Transport for People with Disabilities (PTAO; d:VböV; f:OTHand)**

## **in force since 2<sup>nd</sup> July 2006 :**

- **DETEC Ordinance on the technical requirements for the Adaptation of Public Transport for disabled persons (PTTRO; d:VAböV; f:OETHand)**

**DETEC = Department for Environment, Transport, Energy and Communication (d:UVEK; f:DETEC)**

## **General principles of the DDA (d:BehiG; f:LHand)**

People with disabilities have the same needs for and rights to independent mobility as people without impairments

### **Overcoming barriers**

- **for the access to buildings and facilities**
- **for using services**
- **for the access to education and employment**
- **in public transport**

## **DDA's principles regarding public transport**

- **Independent and as far as possible spontaneous use of accessible public transport**
- **Assistance through public transport personal is permitted**
- **People with disabilities:**
  - **Hearing impaired (incl. deaf) people**
  - **Visually impaired (incl. blind) people**
  - **Physically handicapped (incl. wheelchair users) people**
  - **Mentally handicapped people**
- **Regardless of the reasons of the impairment**

## **Key features of the DDA regarding public transport (I)**

- **Area of application: licensed transport operators of the Confederation**
- **Since 1<sup>st</sup> January 2004, new vehicles and new stops and stations, as well as those that are being upgraded must meet the needs of disabled passengers**
- **existing buildings, equipment and vehicles must be adapted by the end of 2023**
- **customer information system and ticket machines must be adapted by the end of 2013**

## **Key features of the DDA regarding public transport (II)**

- **Federal Council sets rules and regulations for the public transport and adapts them periodically to the technical requirements > DETEC is mandated**
- **Individual right of action for people concerned**
- **Right to appeal for associations of Handicapped; representation through the department „Handicapped and public transport“ (BöV)**
- **Principle of proportionality**

## **Key features PTAO (I) (VböV / OTHand)**

- **Overview functional requirements (,rough‘ standards):**  
**what means barrier-free public transport,  
which domains and services are concerned?**
- **e.g. buildings, equipments, vehicles, toilets  
in train stations, etc.**

## **Details of regulatory statutes**

### **PTTRO (VAböV/OETHand):**

- **Detailed specification for public transport**
- **Specific standards for buses and funiculars**
- **AB-EBV (Railways Ordinance):**
  - **Specific standards for trains and tramways**
- **AB-SBV (Shipbuilding Ordinance):**
  - **Specific standards for boats and landing piers**

## **Standards' examples of PTTRO (I) (VAböV/OETHand)**

### **Deadline for the modifications: december 2013**

- **font size, color and construct for printed information and electronic announcements**
- **visual as well as audible customer information in vehicles and at relevant stops (with massive passengers' flow)**
- **Configuration of ticket machines**

## Standards' examples of AB-EBV (Railways Ordinance)

**Deadline for the modifications: december 2023**

- **Max. inclination for the ramps in percent**
- **Conditions for the step free access to trains and tramways for wheelchairs and rollators**
- **Security lines on platforms: prescriptions on contrast and tactility of strips for visually-impaired passengers**

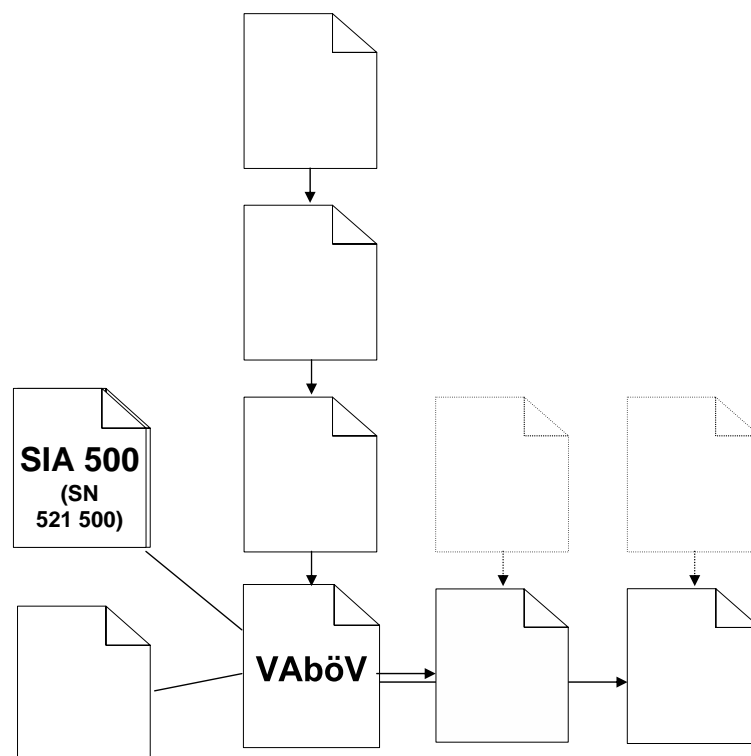



**[www.bav.admin.ch/mobile](http://www.bav.admin.ch/mobile)**

**[mobile@bav.admin.ch](mailto:mobile@bav.admin.ch)**